



TAIGONG
— 泰工减速机 —

江苏泰工机械设备有限公司
Jiangsu Taigong Machinery Equipment Co., Ltd.

地址：江苏省无锡市梁溪区凤凰城29号

电话：0510-80215222

传真：0510-82601236

邮箱：158553680@qq.com

技术支持：13961848999



1 概述 >>>>>

KW系列锥面包络圆柱蜗杆减速器 (JB/T5559-1991) 采用ZK1蜗杆, 即锥面包络圆柱蜗杆, 承载能力较大, 传动效率高, 使用寿命长。主要适用于冶金、矿山、起重、运输、化工、建筑、轻工等行业。

工作条件: 蜗杆输入转速不超过1500r/min; 工作环境温度为-40~40℃, 当工作环境温度低于0℃时, 启动前润滑油必须加热到0℃以上, 或采用低凝固点的润滑油; 减速器可正、反双向运转。

2 型号、中心距、传动比、标记 >>>>>

2.1 型号

- (1) **KWU**型—蜗杆在蜗轮之下的锥面包络圆柱蜗杆减速器;
- (2) **KWS**型—蜗杆在蜗轮之侧的锥面包络圆柱蜗杆减速器;
- (3) **KWO**型—蜗杆在蜗轮之上的锥面包络圆柱蜗杆减速器。

其中 **K**—蜗杆为ZK1型, **W**—蜗杆减速器, **U**—蜗杆在蜗轮之下, **S**—蜗杆在蜗轮之侧, **O**—蜗杆在蜗轮之上。

2.2 中心距

KW型蜗杆减速器中心距

中心距代号	1	2	3	4	5	6	7	8	9	10	11	12
中心距a/mm	32	40	50	63	80	100	125	160	180	200	225	250

2.3 公称传动比

KW型蜗杆减速器传动比

传动比代号	1	2	3	4	5	6	7	8	9	10
传动比i	7.5	10	12.5	15	20	25	30	40	50	60

2.4 标记示例

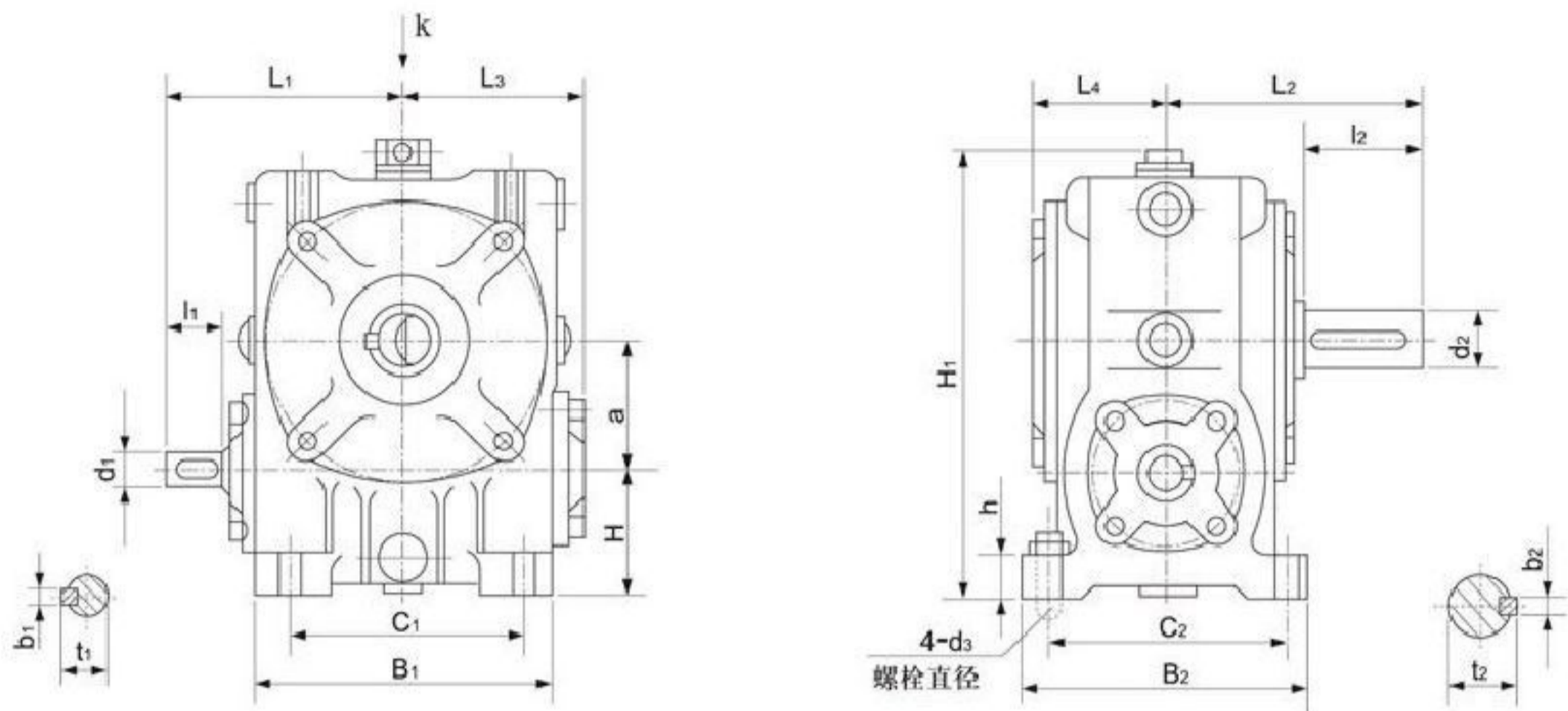

3 外形及安装尺寸 >>>>>
KWU型减速器外形尺寸及装配型式

装配型式 从k向看

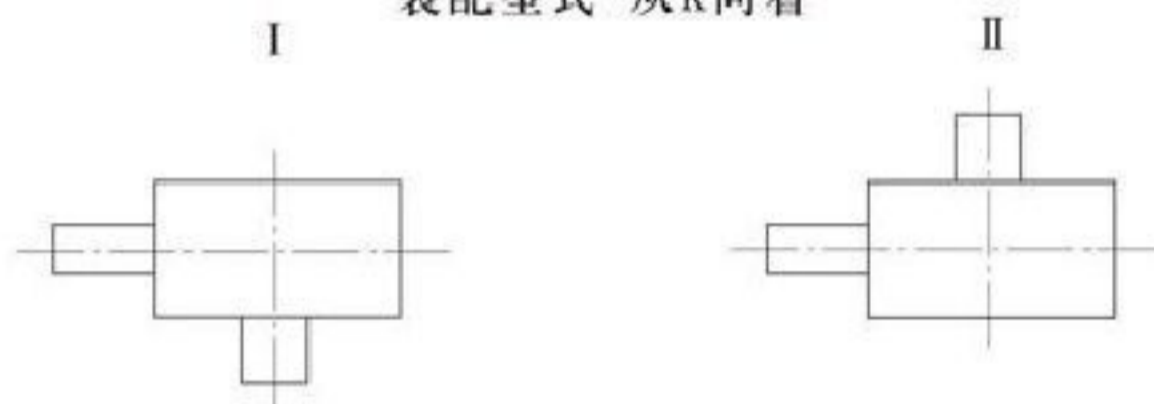

mm

型号 \ 尺寸	a	B ₁	B ₂	C ₁	C ₂	h	H	H ₁	d ₃	d ₁ (j6)	l ₁	b ₁
KWU32	32	97	88	75	75	10	36	124	M5	12	25	4
KWU40	40	110	98	85	82	12	45	156	M6	14	25	5
KWU50	50	130	120	100	100	15	48	182	M8	16	28	5
KWU63	63	146	140	115	120	16	60	223	M10	18	28	6
KWU80	80	175	170	140	145	20	71	270	M12	22	36	6
KWU100	100	210	200	170	170	24	80	324	M12	24	36	8

型号 \ 尺寸	t ₁	L ₁	d ₂	l ₂	b ₂	t ₂	L ₂	L ₃	L ₄	质量kg(不含油量)
KWU32	135	78	16j6	28	5	18	80	-	43	3.5
KWU40	16	84	20j6	36	6	22.5	95	-	49	7
KWU50	18	98	22j6	36	8	24.5	105	-	57	9
KWU63	20.5	118	30j6	58	8	33	136	86	65	16
KWU80	24.5	146	38k6	58	10	41	158	105	84	28
KWU100	27	165	40k6	82	12	43	190	123	95	43

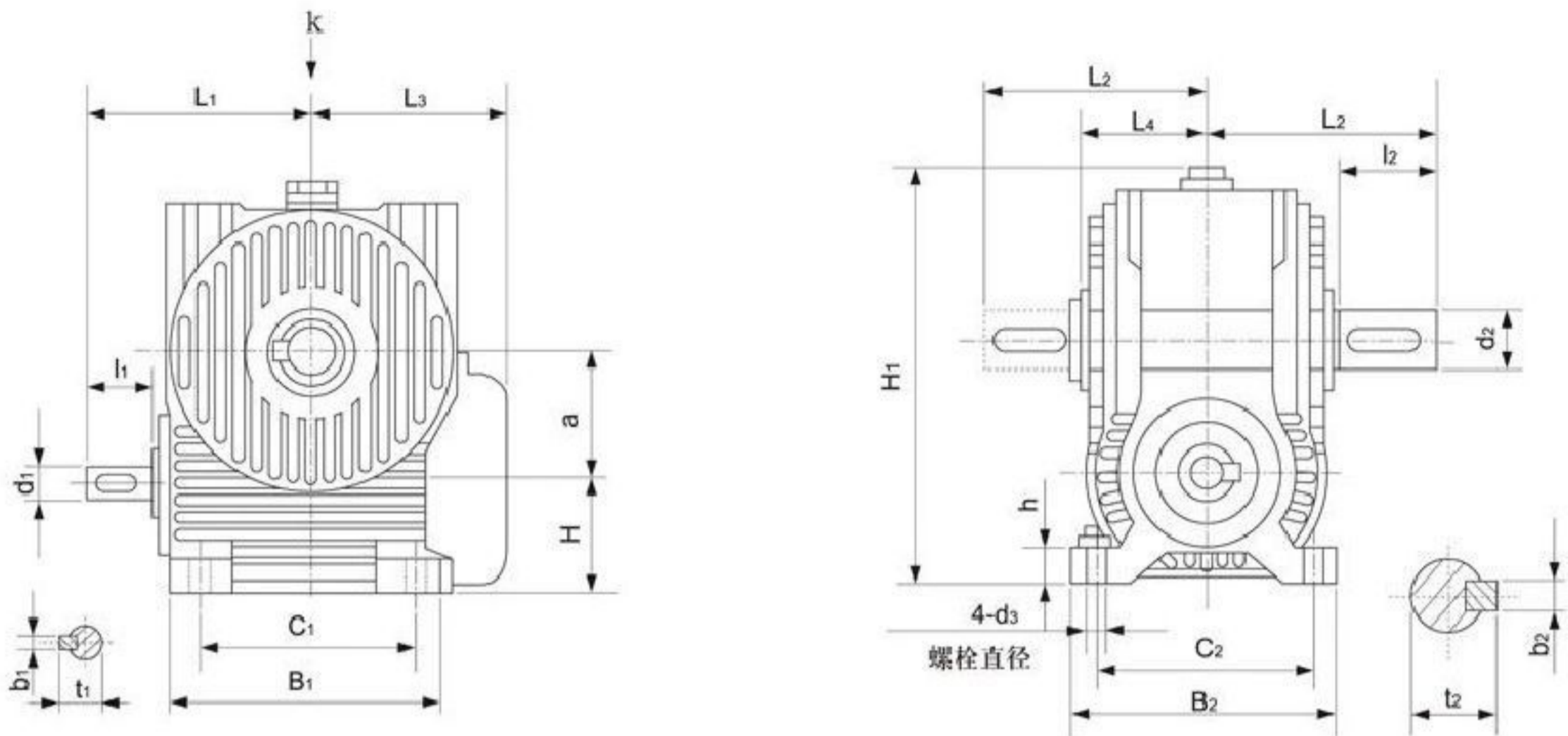
KWU型减速器外形及装配型式

装配型式(F-带风扇) 从k向看

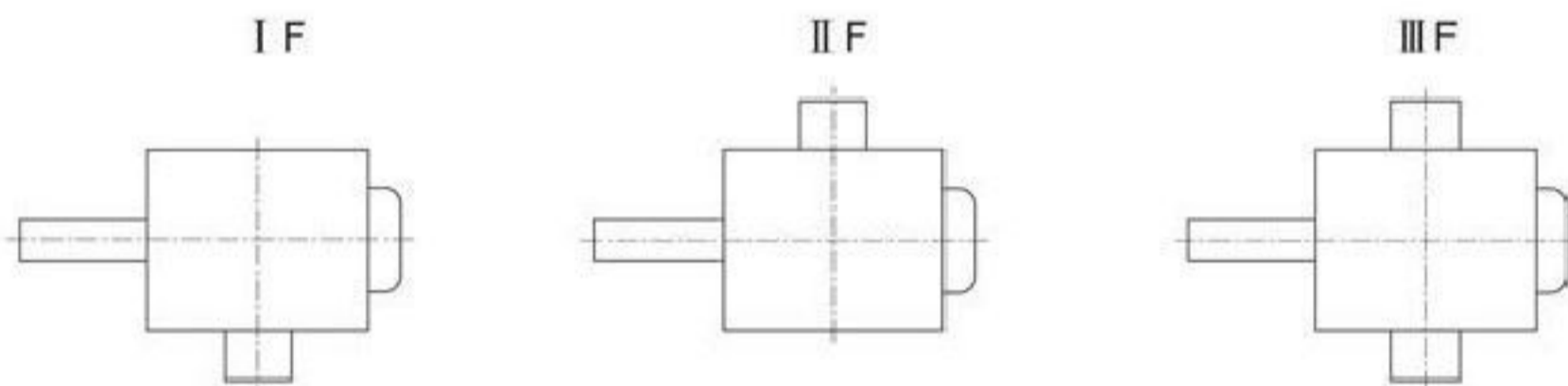

mm

型号 \ 尺寸	a	B ₁	B ₂	C ₁	C ₂	h	H	H ₁	d ₃	d ₁	l ₁	b ₁
KWU125	125	270	245	220	210	32	112	418	M16	32k6	58	10
KWU160	160	325	295	270	255	40	140	524	M16	42k6	82	12
KWU180	180	368	325	290	280	45	160	578	M20	45k6	82	14
KWU200	200	410	350	315	295	50	170	623	M20	48k6	82	14
KWU225	225	450	380	350	325	55	190	690	M24	48k6	82	14
KWU250	250	500	415	435	355	65	200	765	M24	55m6	82	16

型号 \ 尺寸	t ₁	L ₁	d ₂ (m6)	l ₂	b ₂	t ₂	L ₂	L ₃	L ₄	质量kg(不含油量)
KWU125	35	218	55	82	16	59	215	202	125	70
KWU160	45	276	65	105	18	69	266	242	157	130
KWU180	48.5	300	75	105	20	79.5	280	267	167	180
KWU200	51.5	324	80	130	22	85	321	299	185	247
KWU225	51.5	342	90	130	25	95	337	320	198	301
KWU250	59	374	100	165	28	106	390	343	219	406

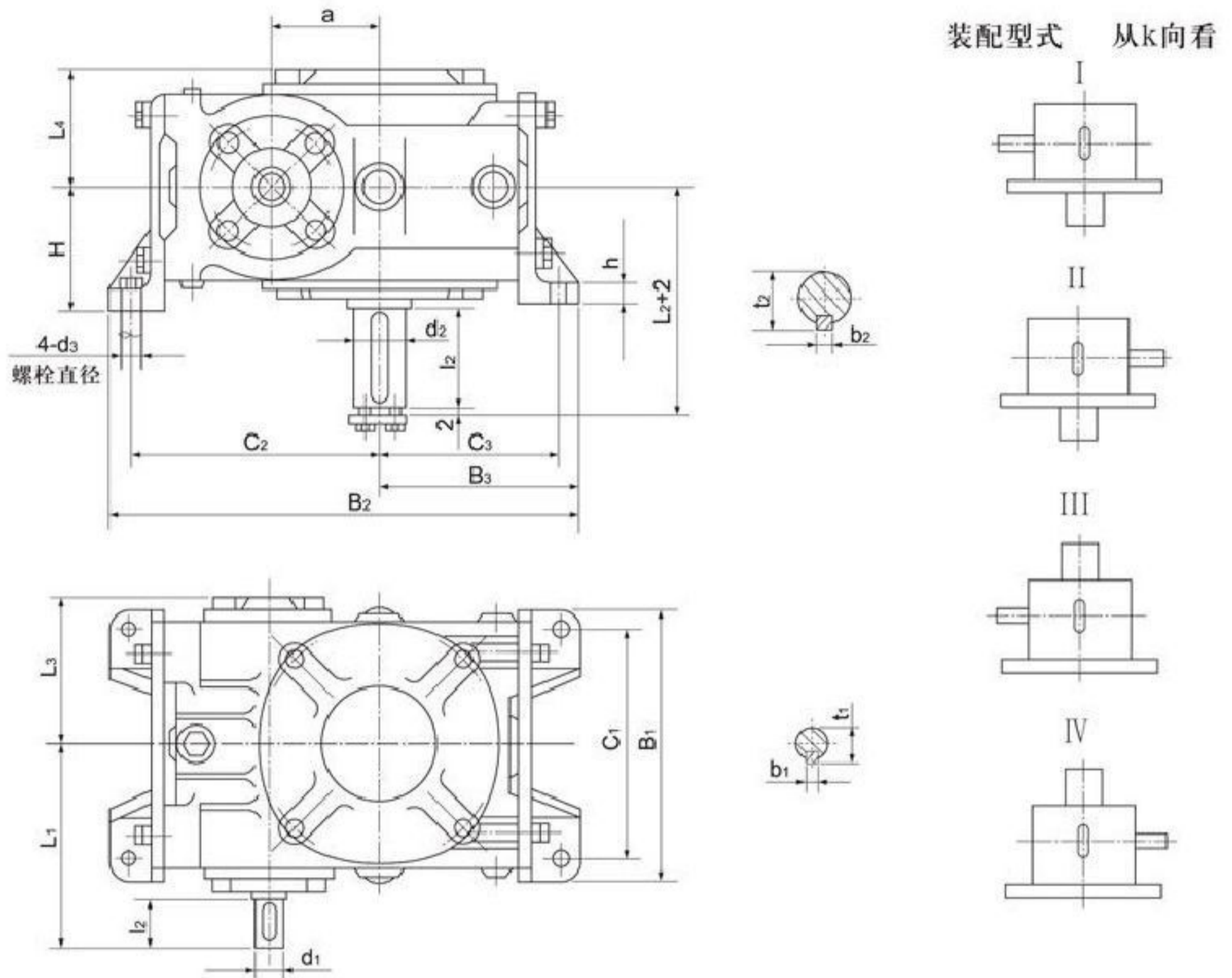
KWS型减速器外形尺寸及装配型式

mm

型号 \ 尺寸	a	B ₁	B ₂	B ₃	C ₁	C ₂	C ₃	d ₁ (j6)	l ₁	b ₁	t ₁	L ₁
KWS32	32	105	157	66	85	81	56	12	25	4	13.5	78
KWS40	40	120	193	84	95	101	76	14	25	5	16	84
KWS50	50	140	225	87	120	118	87	16	28	5	18	98
KWS63	63	160	269	111	140	146	99	18	28	6	20.5	118
KWS80	80	195	331	140	160	176	125	22	36	6	24.5	146
KWS100	100	230	384	164	190	205	149	24	36	8	27	165

型号 \ 尺寸	d ₂	l ₂	b ₂	t ₂	L ₂	L ₃	L ₄	h	H	d ₃	质量kg(不含油量)
KWS32	16j6	28	5	18	80	-	44	10	56	M5	4
KWS40	20j6	36	6	22.5	95	-	50	12	63	M6	8
KWS50	22j6	36	8	24.5	105	-	58	15	71	M8	11
KWS63	30j6	58	8	33	128	86	65	16	75	M10	19
KWS80	38k6	58	10	41	158	105	85	20	100	M12	32
KWS100	40k6	82	12	43	190	123	96	24	112	M12	54

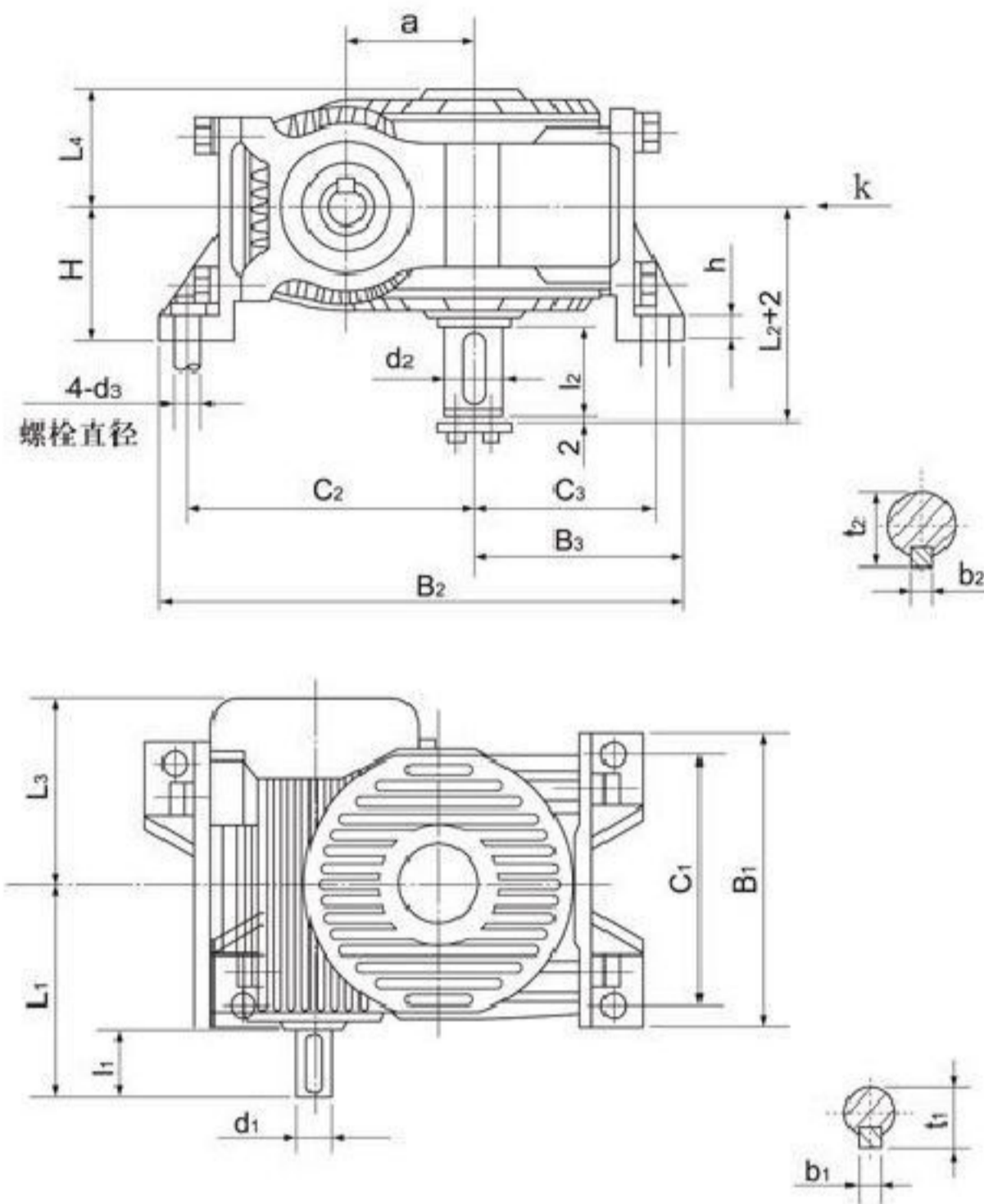
KWS型减速器外形尺寸及装配型式

装配型式(F-带风扇) 从k向看

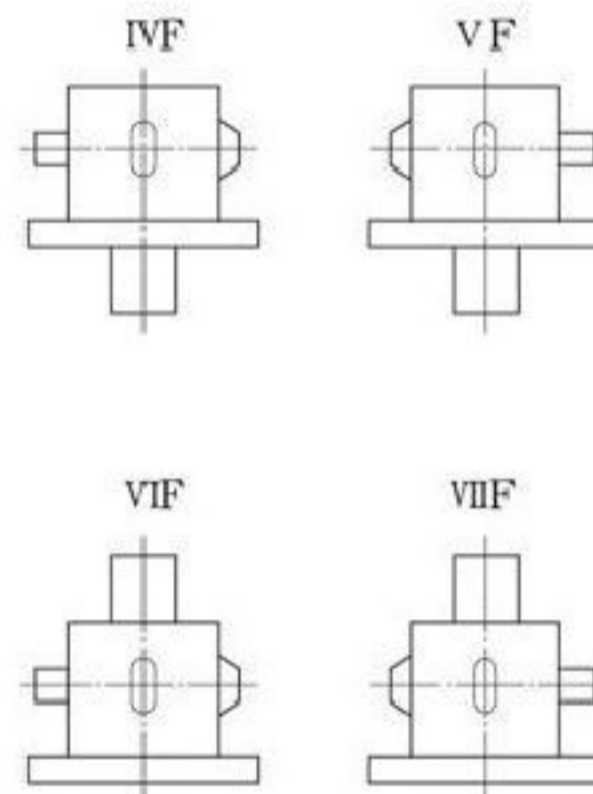

mm

型号	尺寸	a	B ₁	B ₂	B ₃	C ₁	C ₂	C ₃	d ₁	l ₁	b ₁	t ₁	L ₁
KWS125		125	290	501	211	245	272	193	32k6	58	10	35	218
KWS160		160	350	605	245	300	360	235	42k6	82	12	45	270
KWS180		180	390	690	280	330	385	255	45k6	82	14	48.5	300
KWS200		200	430	739	300	370	420	275	48k6	82	14	51.5	324
KWS225		225	470	815	325	380	465	300	48k6	82	14	51.5	342
KWS250		250	525	895	365	430	510	345	55m6	82	16	59	374

型号	尺寸	d ₂ (m6)	l ₂	b ₂	t ₂	L ₂	L ₃	L ₄	h	H	d ₃	质量kg(不含油量)
KWS125		55	82	16	59	215	202	125	32	140	M16	82
KWS160		65	105	18	69	266	242	155	40	180	M16	150
KWS180		75	105	20	79.5	280	267	167	45	190	M20	210
KWS200		80	130	22	85	321	299	185	50	200	M20	278
KWS225		90	130	25	95	337	320	198	55	225	M24	365
KWS250		100	165	28	106	390	343	219	65	250	M24	480

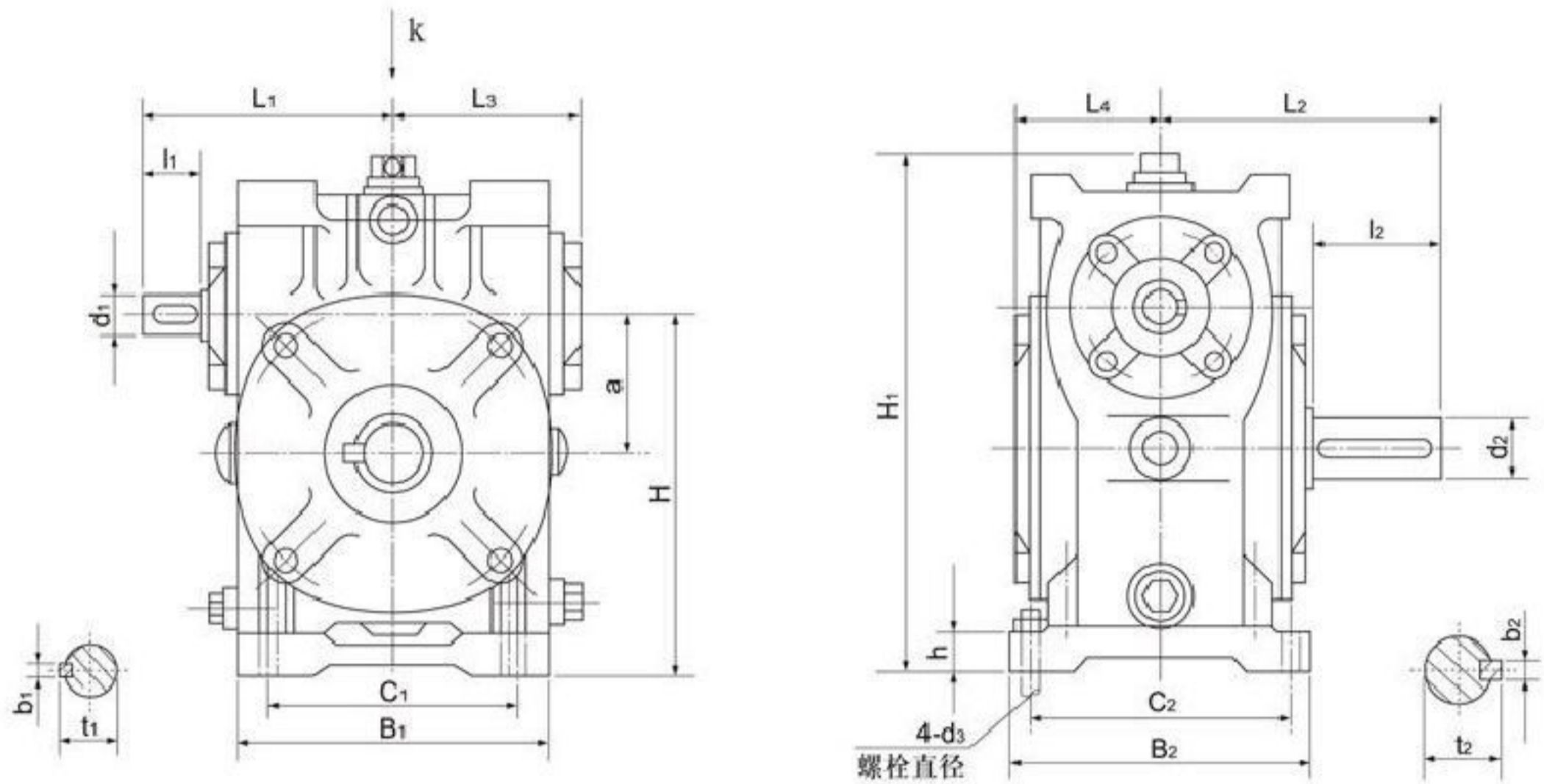
KWO型减速器外形尺寸及装配型式

装配型式 从k向看

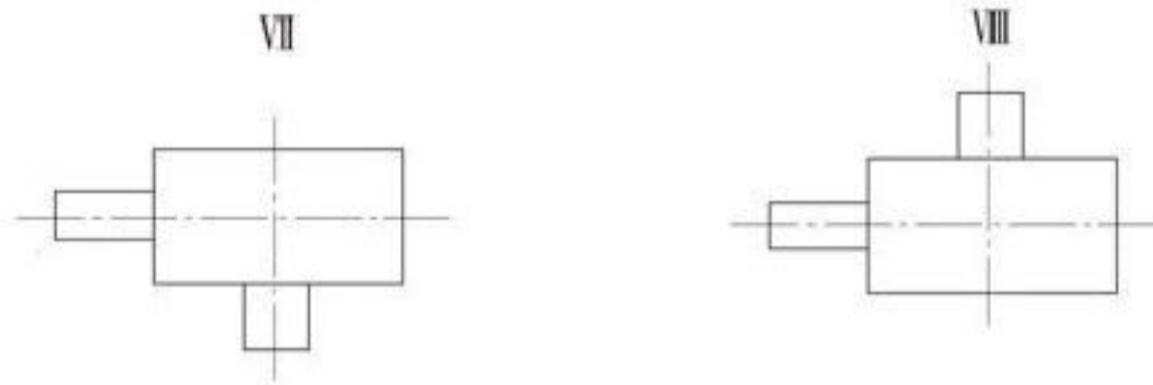

mm

型号	尺寸	a	B ₁	B ₂	C ₁	C ₂	h	H	H ₁	d ₃	d ₁ (j6)	l ₁	b ₁
KWO32		32	97	88	75	75	10	90	126	M5	12	25	4
KWO40		40	110	98	85	82	12	112	156	M6	14	25	5
KWO50		50	130	120	100	100	15	132	189	M8	16	28	5
KWO63		63	146	140	115	120	16	160	221	M10	18	28	6
KWO80		80	175	170	140	145	20	200	270	M12	22	36	6
KWO100		100	210	200	170	170	24	250	339	M12	24	36	8

型号	尺寸	t ₁	L ₁	d ₂	l ₂	b ₂	t ₂	L ₂	L ₃	L ₄	质量kg(不含油量)
KWO32		13.5	78	16j6	28	5	18	80	-	43	3.8
KWO40		16	84	20j6	36	6	22.5	95	-	49	7.5
KWO50		18	98	22j6	36	8	24.5	105	-	57	10
KWO63		20.5	118	30j6	58	8	33	136	86	65	17
KWO80		24.5	146	38k6	58	10	41	158	105	84	29.5
KWO100		27	165	40k6	82	12	43	190	123	95	47

KWO型减速器外型尺寸及装配型式

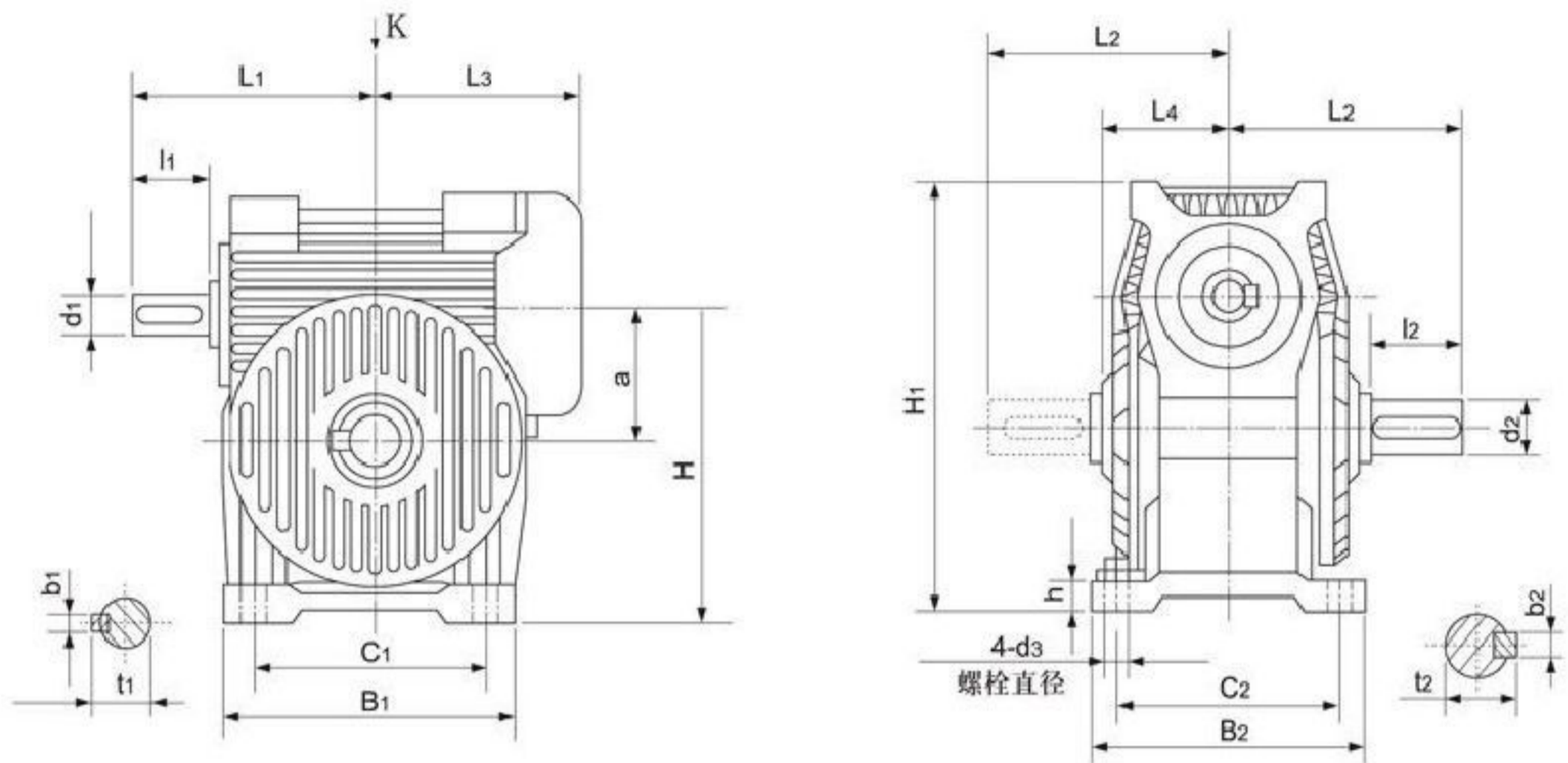

装配型式(F-带风扇)
从K向看

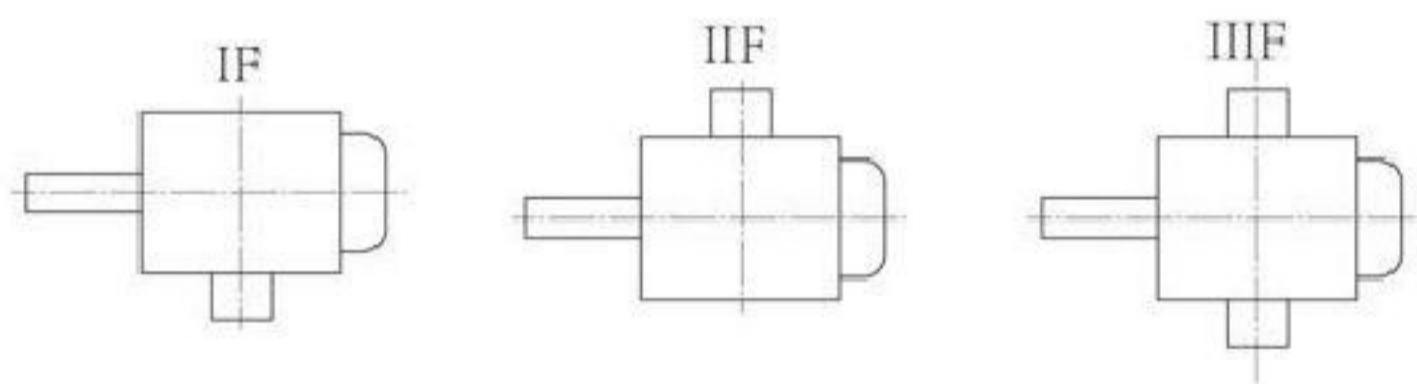

mm

型号	尺寸	a	B ₁	B ₂	C ₁	C ₂	h	H	H ₁	d ₃	d ₁	l ₁	b ₁
KWO125		125	270	245	220	210	32	315	424	M16	32k6	58	10
KWO160		160	325	295	270	255	40	385	525	M16	42k6	82	12
KWO180		180	368	325	290	280	45	435	595	M20	45k6	82	14
KWO200		200	410	325	315	295	45	475	645	M20	48k6	82	14
KWO225		225	450	380	350	325	55	530	720	M24	48k6	82	14
KWO250		250	500	415	435	355	65	600	800	M24	55k6	82	16

型号	尺寸	t ₁	L ₁	d ₂ (M6)	l ₂	b ₂	t ₂	L ₂	L ₃	L ₄	质量kg(不含油量)
KWO125		35	218	55	82	16	59	215	202	125	75
KWO160		45	276	65	105	18	69	266	242	155	138
KWO180		48.5	300	75	105	20	79.5	280	267	167	192
KWO200		51.5	324	80	130	22	85	321	299	185	264
KWO225		51.5	342	90	130	25	95	337	320	198	330
KWO250		59	374	100	165	28	106	390	343	219	450

4 输入功率与输出转矩 >>>>>

KW型蜗杆减速器额定输入功率及额定输出转矩表

传动比代号	公称传动比 i	输入转速 n ₁ /r·min	中心距代号	1	2	3	4	5	6	7	8	9	10	11	12	
			中心距 a/mm	32	40	50	63	80	100	125	160	180	200	225	250	
			型号	KWU、KWS、KWO												
			额定输入功率P ₁ /kw 额定输出转矩T ₂ /N·m													
1	7.5	1500	P ₁	-	0.76	1.16	1.98	3.22	7.62	15.61	19.98	32.54	42.51	50.86	64.56	
			T ₂	-	28.7	44.1	80.1	142.6	343.6	700	900	1370	1925	2160	3000	
		1000	P ₁	-	0.59	0.90	1.40	2.30	6.14	11.10	16.66	24.11	38.26	42.24	54.34	
			T ₂	-	33.2	50.6	84.3	149.7	406.1	730	1100	1520	2600	2670	3700	
		750	P ₁	-	0.49	0.77	1.15	1.88	5.29	8.59	14.45	18.89	31.74	35.83	42.05	
			T ₂	-	36.5	57.2	91.31	161.74	462.4	750	1270	1570	2835	3020	3820	
	500	P ₁	-	0.36	0.63	0.90	1.48	4.18	6.28	10.97	13.44	23.29	29.69	36.05		
		T ₂	-	40.1	70.1	106.4	187.9	539.8	810	1430	1650	3000	3680	4850		
	2	10	1500	P ₁	0.33	0.65	1.12	1.90	3.13	5.77	14.30	25.01	30.67	35.82	49.17	58.19
				T ₂	16.5	30.6	55.9	100.1	170.0	335.3	840	1480	1680	2120	2720	3470
			1000	P ₁	0.26	0.48	0.82	1.37	2.19	4.17	10.36	18.22	22.14	26.43	36.44	42.71
				T ₂	19.2	33.7	61.4	107.6	177.7	358.2	900	1610	1800	2320	3010	3780
750			P ₁	0.23	0.38	0.66	1.15	1.79	3.51	8.39	13.99	17.02	20.46	28.55	35.19	
			T ₂	21.9	36.0	65.6	118.0	191.7	399.1	960	1630	1830	2370	3120	4160	
500		P ₁	0.18	0.29	0.49	0.92	1.40	2.95	6.64	10.14	12.35	14.49	20.31	24.36		
		T ₂	25.9	39.4	71.8	139.4	222.3	499.1	1120	1730	1950	2460	2360	4210		
3		12.5	1500	P ₁	-	-	0.84	1.48	3.05	4.81	11.68	19.56	30.84	31.23	44.72	55.40
				T ₂	-	-	55.1	101.7	206.7	360.5	860	1500	2140	2400	3030	4160
			1000	P ₁	-	-	0.62	1.10	2.05	3.44	8.75	16.46	22.15	28.21	32.97	40.69
				T ₂	-	-	60.5	111.7	223.1	378.4	940	1860	2280	3230	3320	4540
	750		P ₁	-	-	0.51	0.96	1.69	2.81	7.06	13.44	17.08	21.55	25.67	32.63	
			T ₂	-	-	64.5	129.1	243.3	409.3	1000	2010	2320	3250	3410	4840	
	500	P ₁	-	-	0.37	0.76	1.24	2.20	6.15	9.86	12.44	15.33	18.13	22.76		
		T ₂	-	-	70.4	149.9	265.3	473.9	1290	2170	2490	3450	3530	4930		
	4	15	1500	P ₁	-	0.50	0.75	1.42	2.35	4.05	10.57	19.56	27.54	32.89	47.38	49.89
				T ₂	-	34.0	51.8	104.6	190.5	342.0	900	1650	2430	2955	4200	4400
			1000	P ₁	-	0.39	0.59	1.08	1.63	3.19	7.89	14.39	20.44	24.97	35.00	41.28
				T ₂	-	39.7	60.0	117.8	196.0	391.5	980	1800	2660	3325	4610	5500
750			P ₁	-	0.32	0.51	0.95	1.33	2.62	7.42	13.20	16.49	20.82	26.75	35.36	
			T ₂	-	42.7	68.2	135.7	210.0	421.4	1200	2150	2840	3670	4650	6260	
500		P ₁	-	0.23	0.42	0.72	1.04	2.07	5.69	10.56	12.18	16.50	19.29	26.73		
		T ₂	-	46.5	84.0	153.7	242.2	487.2	1350	2470	3090	4260	4930	6980		
5		20	1500	P ₁	-	0.41	0.72	1.34	2.25	3.43	8.34	14.20	23.24	24.60	38.28	43.65
				T ₂	-	36.0	65.6	129.4	223.6	376.5	930	1600	2450	2825	4090	4980
			1000	P ₁	-	0.31	0.53	0.98	1.69	2.43	6.79	10.43	16.75	21.33	28.28	31.68
				T ₂	-	39.4	71.8	137.0	248.2	387.3	1100	1730	2580	3600	4490	5340
	750		P ₁	-	0.24	0.42	0.81	1.43	1.98	5.55	8.59	14.33	18.10	23.14	25.40	
			T ₂	-	41.9	76.3	149.1	273.6	414.9	1180	1850	2880	4050	4810	5670	
	500	P ₁	-	0.18	0.31	0.61	1.16	1.56	4.26	6.72	10.66	14.38	18.38	18.64		
		T ₂	-	45.4	82.7	164.6	319.9	478.6	1320	2100	3130	4635	5550	6000		

KW型蜗杆减速器额定输入功率及额定输出转矩续表

传动比代号	公称传动比 i	输入转速 n _i /r·min	中心距代号	1	2	3	4	5	6	7	8	9	10	11	12	
			中心距 a/mm	32	40	50	63	80	100	125	160	180	200	225	250	
			型号	KWU、KWS、KWO												
			额定输入功率P ₁ /kw 额定输出转矩T ₂ /N·m													
6	25	1500	P ₁	0.22	-	0.55	0.95	1.86	3.18	5.94	10.16	13.62	17.52	24.81	29.68	
			T ₂	22.6	-	64.5	119.1	243.3	429.7	790	1425	1750	2500	3155	4195	
		1000	P ₁	0.16	-	0.41	0.69	1.36	2.25	4.80	8.67	12.95	15.80	18.00	23.18	
			T ₂	24.4	-	70.4	129.9	265.3	445.7	950	1815	2460	3320	3390	4845	
		750	P ₁	0.13	-	0.32	0.56	1.09	1.82	4.52	8.35	10.66	13.00	14.72	18.02	
			T ₂	25.9	-	74.6	137.7	281.0	480.0	1160	2295	2660	3600	3645	4950	
	500	P ₁	0.09	-	0.23	0.41	0.80	1.44	3.30	6.71	8.35	10.17	11.45	13.58		
		T ₂	26.3	-	80.5	148.6	303.0	556.8	1250	2690	3045	4100	4110	5520		
	7	30	1500	P ₁	0.18	0.34	0.51	0.98	1.58	2.64	5.28	11.67	13.18	19.02	20.75	21.15
				T ₂	21.4	41.3	62.7	121.9	226.1	387.4	808	1780	2010	3000	3305	3475
			1000	P ₁	0.14	0.27	0.40	0.71	1.19	1.92	4.06	8.54	10.74	14.22	15.13	15.45
				T ₂	24.7	48.3	71.7	128.3	247.7	414.3	900	1900	2350	3280	3525	3730
750			P ₁	0.12	0.24	0.34	0.62	1.04	1.76	3.39	7.42	8.45	11.29	12.10	12.69	
			T ₂	27.0	54.4	78.8	141.2	281.84	488.6	950	2100	2470	3410	3685	3980	
500		P ₁	0.09	0.17	0.28	0.48	0.80	1.31	2.74	5.69	6.94	8.68	8.74	9.92		
		T ₂	30.1	57.8	95.4	160.5	316.6	524.3	1100	2300	2810	3680	3875	4570		
8		40	1500	P ₁	-	0.26	0.35	0.94	1.64	2.33	4.91	8.46	11.58	15.64	19.08	26.93
				T ₂	-	38.9	55.3	149.5	262.1	447.8	960	1700	2160	3160	3605	5630
			1000	P ₁	-	0.22	0.32	0.68	1.17	1.63	3.85	7.08	8.66	12.90	14.13	20.18
				T ₂	-	46.1	72.1	155.9	268.8	450.1	1075	2000	2325	3810	3915	6170
	750		P ₁	-	0.18	0.30	0.56	0.93	1.33	3.17	5.88	7.19	10.60	11.67	16.06	
			T ₂	-	49.9	87.9	168.6	276.9	477.9	1150	2200	2505	4000	4145	6430	
	500	P ₁	-	0.13	0.21	0.42	0.72	1.05	2.52	4.65	5.68	8.42	9.18	11.68		
		T ₂	-	54.0	91.5	185.5	315.5	546.7	1325	2500	2885	4700	4800	6900		
	9	50	1500	P ₁	0.15	0.24	0.30	0.67	1.30	1.89	4.02	6.20	10.77	12.06	15.46	18.92
				T ₂	25.1	41.1	56.2	137.7	281.0	439.3	940	1520	2400	3000	3520	4810
			1000	P ₁	0.11	0.20	0.27	0.50	0.97	1.49	3.54	5.45	8.32	10.03	11.53	14.08
				T ₂	28.7	49.3	74.7	148.6	303.0	508.8	1200	1900	2720	3660	3845	5270
750			P ₁	0.09	0.16	0.23	0.41	0.78	1.23	2.88	4.92	6.92	8.72	9.57	11.67	
			T ₂	31.4	51.3	84.1	156.0	318.0	543.8	1280	2250	2960	4210	4165	5725	
500		P ₁	0.06	0.14	0.16	0.29	0.57	0.97	2.13	4.03	5.48	7.20	7.55	9.20		
		T ₂	34.2	54.9	87.1	165.8	337.6	626.3	1400	2750	3415	5000	4800	6600		
10		60	1500	P ₁	-	0.22	0.25	0.43	1.09	1.59	3.25	4.89	7.60	9.77	10.60	13.10
				T ₂	-	43.6	56.2	97.8	256.4	390.0	852	1300	2095	2800	3010	3800
			1000	P ₁	-	0.16	0.23	0.34	0.82	1.19	2.63	4.14	6.41	7.35	8.34	11.48
				T ₂	-	46.2	75.4	113.5	275.0	428.9	1000	1600	2615	3100	3490	4830
	750		P ₁	-	0.13	0.20	0.33	0.68	1.07	2.24	3.79	5.50	7.21	7.87	9.53	
			T ₂	-	48.3	84.0	136.4	290.4	462.6	1100	1900	2830	3820	4100	5200	
	500	P ₁	-	0.09	0.15	0.27	0.52	0.80	1.93	3.16	4.52	5.55	6.30	7.52		
		T ₂	-	51.1	87.6	167.6	330.7	513.6	1340	2250	3290	4150	4735	6100		